



HortiFlora

International Horticulture & Floriculture Trade Fair

**8TH BIENNIAL INTERNATIONAL TRADE EXPO FOR THE
ETHIOPIAN HORTICULTURE & FLORICULTURE INDUSTRY**

**WEDNESDAY MARCH 8 TO FRIDAY MARCH 10 • 2023
MILLENNIUM HALL • ADDIS ABABA • ETHIOPIA**

EXHIBITOR MANUAL

Updated: 24/01/2023 5:17 PM

Organized and managed by:



With the support of:



INDEX

	Page
1. GENERAL INFORMATION	
1.1 VENUE ADDRESS	3
1.2 IMPORTANT TIMES & DATES	3
1.3 EXHIBITION BADGES.....	3
1.4 EXHIBITION DIRECTORY	4
1.5 ADDITIONAL PROMOTION TOOLS.....	4
1.6 OTHER SERVICES	4
1.7 VISITOR ADMISSION POLICY	4
1.8 FLOWER DESIGNING	4
2. STAND CONSTRUCTION, FURNISHINGS & OTHERS	
2.1 STAND CONSTRUCTION PACKAGE DETAILS	5
2.2 RENTAL OF FURNISHINGS & OTHERS.....	6
2.3 STAND CLEANING.....	6
2.4 INDEMNITY FORM.....	6
2.5 INSURANCE	6
3. CUSTOMS CLEARANCE	6
4. OBLIGATORY ORDER FORMS	
ORDER FORM 1 OBLIGATORY SET UP & BREAK DOWN BADGES	8
ORDER FORM 2 OBLIGATORY EXHIBITOR BADGES.....	9
ORDER FORM 3 OBLIGATORY EXHIBITOR DIRECTORY LISTING	10
ORDER FORM 4 OBLIGATORY FASCIA BOARD TEXT FOR YOUR STAND.....	11
ORDER FORM 5 OBLIGATORY INDEMNITY FORM	12
5. NON-OBLIGATORY ORDER FORMS	
ORDER FORM 6 ADVERTISING	14
ORDER FORM 7 WEBSITE LINK	15
ORDER FORM 8 CUSTOMER INVITATION LINK	16
ORDER FORM 9 ELECTRICAL OUTLETS	17
ORDER FORM 10A FURNISHINGS	18
ORDER FORM 10B FURNISHINGS	19
ORDER FORM 11 AUDIOVISUALS & SUPPLIES	20
ORDER FORM 12 STORAGE IN YOUR STAND	21
ORDER FORM 13 FLOWER DESIGNING	22

1. GENERAL INFORMATION

1.1. VENUE ADDRESS

Millennium Hall
Bole, Addis Ababa
Ethiopia

Millennium hall is one of the most desirable trade fair venues in northeast Africa. It spreads across 87,000 sqm of landscape with an indoor space of 19,000sqm offering a huge expo hall stretched up to 5000sqm, 4 conference rooms, parking facilities, round the clock security. The hall is very close and easily accessible from the Addis Ababa International Airport and there are multiple four and five star rated according to UNWTO standard hotels found nearby made it to be one of the best venues for conducting regional and international exhibitions/trade fairs, conferences, seminars, private functions & events, etc in Addis Ababa..

1.2. IMPORTANT TIMES & DATES

- **SET UP (BUILD UP).**
Monday March 6 08:00 a.m. - 06:00 p.m.
Tuesday March 7 08:00 a.m. - 06:00 p.m.
All exhibits must be set up by 06:00 p.m. on Tuesday evening, March 7..
- **BREAK DOWN (MOVE OUT).**
Friday March 10 04:00 p.m. - 06:00 p.m.
Saturday March 11 08:00 a.m. - 06:00 p.m.
- **HOURS TO REFRESH AND/OR REDESIGN YOUR FLOWERS.**
Wednesday March 8 09:00 a.m. - 10:00 a.m.
Thursday March 9 09:00 a.m. - 10:00 a.m.
Friday March 10 09:00 a.m. - 10:00 a.m.
- **EXHIBITION DAY TO DAY PROGRAMME**
Wednesday March 8 10:00 a.m. - 10:30 a.m.
Official opening ceremony
10:30 a.m.- 06:00 p.m.
Exhibition hours for trade visitors only.
Thursday March 9 10:00 a.m. - 06:00 p.m.
Exhibition hours for trade visitors only.
Friday March 10 10:00 a.m. - 04:00 p.m.
Exhibition hours for trade visitors only.

1.3. EXHIBITION BADGES

- **SET UP & BREAK DOWN BADGES.**
The set up & break down badge is a personal identification and it will give you access to the hall ONLY during set up and break down hours. It WILL NOT give access during exhibition hours.

Every exhibiting company will receive the required number of set up & break down badges which can be requested through OBLIGATORY ORDER FORM 1 on page 8. Exhibitors are required to send this form back before Friday February 10th.

Please note: All badges are personal, non-transferable and valid only for people over 18 years old. Random ID checks will be executed therefore please carry a valid ID at all times.

Badges can be picked up at the registration desk during the following hours as well as during show hours:

Monday March 6	08:00 a.m. - 06:00 p.m.
Tuesday March 7	08:00 a.m. - 06:00 p.m.
Wednesday March 8	08:00 a.m. - 06:00 p.m.

Please note: If you request an exhibitor badge, you will not need an extra set up and break down badge.

- **EXHIBITOR BADGES.**

The exhibitor badge is your personal identification and it will give you access to the exhibition floor at all time. Every exhibiting company will receive the number of exhibitor badges requested through OBLIGATORY ORDER FORM 2 on page 9. Exhibitors are required to send this form back before Friday February 10th.

Badges can be picked up at the registration desk during the following hours:

Monday March 6	08:00 a.m. - 06:00 p.m.
Tuesday March 7	08:00 a.m. - 06:00 p.m.
Wednesday March 8	09:00 a.m. - 06:00 p.m.
Thursday March 9	08:00 a.m. - 06:00 p.m.
Friday March 10	08:00 a.m. - 06:00 p.m.

Please note: All badges are personal, non-transferable and only for people over 18 years old. Exhibitors must carry a valid ID at all times, as the name on the badge will need to match with the name of your ID.

1.4. EXHIBITION DIRECTORY

- **EXHIBITION DIRECTORY LISTING.**

For HORTIFLORA EXPO 2023 an exhibition directory will be published and distributed among trade visitors. It will contain company name, address and contact details of your company in alphabetical order. The English directory is a practical resource for visitors and is, above all, an intensively used reference book. Inclusion in this official directory is free and can increase exposure for your participation in the fair during and after the event.

Your company will also be included in the product index in alphabetical order.

Please fill out OBLIGATORY ORDER FORM 3 on page 10 of this manual. Exhibitors are required to send this form back before Friday February 10th.

- **ADVERTISING.**

An additional way to highlight your presence at HORTIFLORA EXPO 2023 is to take an advertisement in the exhibition directory. This is optional.

Please fill out NON-OBLIGATORY ORDER FORM 6 on page 14 if you want to publish an advertisement in the exhibition directory. Exhibitors are required to send this form and the artwork back to our offices before Friday February 10th.

1.5. ADDITIONAL PROMOTION TOOLS

- **WEBSITE LINK.**

As an extra tool of advertising, HPP Exhibitions offers you the possibility to have a website link to your own company website. Visitors to the HORTIFLORA EXPO 2023 website can click on your company name in the exhibitor list and will be directly linked to your website/page (www.hortifloraexpo.com). The link provides visitors an opportunity to get acquainted with your company and your line of products and/or services given beforehand.

If you would like to have a website link, please fill out NON-OBLIGATORY ORDER FORM 7 on page 15. Exhibitors are required to send this form back before Friday February 10th.

- **CUSTOMER INVITATION LINK.**

You can order*, free of charge, your personalized customer invitation link, which you can forward to any of your customers who you would like to invite to HORTIFLORA EXPO 2023.

For this option, please fill out the NON-OBLIGATORY ORDER FORM 8 on page 16.

**subject to our visitor admission policy as outlined in paragraph 1.7.*

1.6. OTHER SERVICES

For special stand designs, background printing and decoration of your stand please contact:

HPP Exhibitions:

Contact : Mr. Juan Pablo Camacho

Email : juanpablo@hpp.nl

1.7. VISITOR ADMISSION POLICY

HORTIFLORA EXPO 2023 is a business trade show. Business visitors that qualify are invited to attend free of charge and can register onsite during show hours to obtain a passe-partouts that is valid for all 3 exhibition days.

For further questions regarding visitor registration, you can contact Mr. Jasper van Dijk at: jasper@hpp.nl

1.8. FLOWER DESIGNING

You can request professional flower designing for your stand on HORTIFLORA EXPO 2023. HPP offers the services of its professional team of designers as an extra way to highlight your participation. The service includes: rental of wooden pillar on the colour of choice, vase rental, flower designing, daily maintenance and disposal at the end of the exhibition.

To request flower designs, please fill out NON-OBLIGATORY ORDER FORM 13 on page 22.

2. STAND CONSTRUCTION, FURNISHINGS & OTHERS

2.1. STAND CONSTRUCTION PACKAGE DETAILS

The stand construction package, that is included in your contract, facilitates exhibitors and offers various options to particularize their presentations. The stand is built by professional stand builders.

The Stand Construction Package includes:

- Back- and side system walls (white panels, 2.50 meters high)
 - One, two, three or four fascia boards (depending on the location of the stand), which displays the company name.
 - **CONTRACT DOES NOT INCLUDE CARPET**
 - 1 standard low table + 3 standard chairs per stand;
 - 1 spotlight per every 3 m²
- Please take into account that the back and side walls of your stand are hard white panels of 1 meter width and 2,50 meters height.
 - It is forbidden to damage, drill, paint, and weld or modify in any way the hall floor. You will be charged for any repairs or renewals.
 - It is not allowed to paint, drill, hammer, stick non removal materials hang heavy structures or damage in any other way the panels and/or fascia boards of your stand. You will be charged for any repairs or renewals.

Example of Modular Octanorm Shell Scheme System Construction

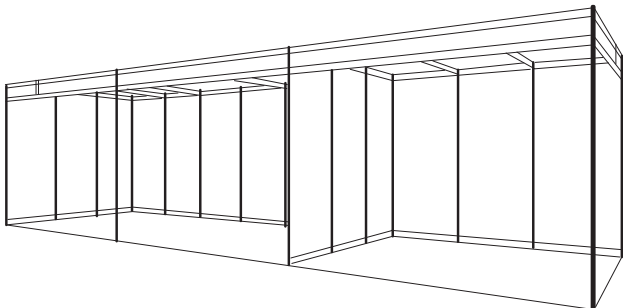

Shell Scheme Dimensions of the Octanorm Stand Construction

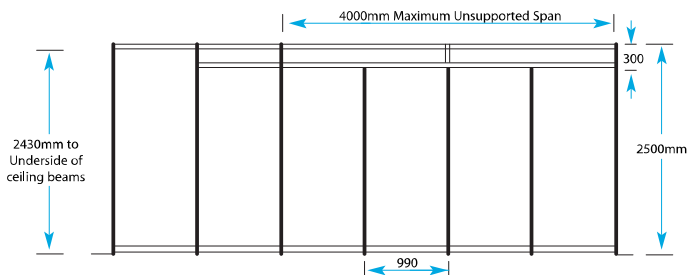

Panel Dimensions of the Octanorm Stand Construction

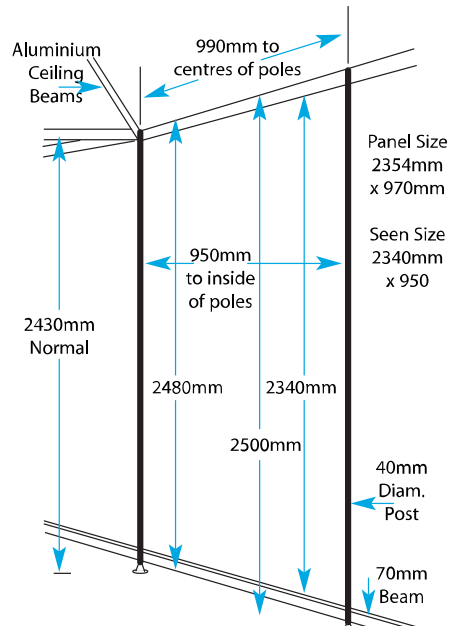

2.2. RENTAL OF FURNISHINGS & OTHERS

- **ELECTRICAL OUTLET.**
If you would like to order outlets for your stand please fill out NON-OBLIGATORY ORDER FORM 9 on page 17. Exhibitors are required to send this form back before Friday February 10th.
- **TABLES, CHAIRS & FURNISHING.**
We have different additional options of tables, chairs and furnishings to choose from, if you want to order any additional or design furniture or refrigerators, please fill out NON-OBLIGATORY ORDER FORM 10A on page 18 or NON-OBLIGATORY ORDER FORM 10B on page 19. Exhibitors are required to send these forms back before Friday February 10th.
- **AUDIOVISUALS & SUPPLIES.**
Additional equipment such as TV's and DVD players will also be available upon request. If you want to order any of these options, please fill out NON-OBLIGATORY ORDER FORM 11 on page 20. Exhibitors are required to send this form back before Friday February 10th.

2.3. STAND CLEANING

The exhibition hall and stands will be cleaned each day before the show opens. Please place your waste basket outside your stand at the end of each day. Cleaners will not be permitted to clean any stand without the explicit request of the exhibitor.

2.4. INDEMNITY FORM

Exhibitors are required to sign the indemnity form. Please fill out OBLIGATORY ORDER FORM 5 on page 12 or. Exhibitors are required to send this form back before Friday February 10th.

2.5. INSURANCE

HPP Exhibitions & EHPEA are not responsible for any loss or damages to your exhibition material related to this exhibition. We recommend you to take insurance for your exhibition materials.

3. CUSTOMS CLEARANCE

For all import and custom clearance matters in to Ethiopia please contact, as soon as possible, the company below:

Mekodi Logistics PLC

Contact: Mr. Amsalu Waleign
Phone: +251-903-434445
E-mail: amsalu.waleign@mekodilogistics.com

Contact: Mr. Dawit Mengistu
Phone: +254-911-514936
E-mail: mekodilogistics@gmail.com

IMPORTANT WARNING!

In order to have your exhibition goods custom cleared in to Ethiopia on time, we urge your company to send a detailed packing list and invoice to the contact person mentioned above, ASAP.

Make sure that the goods listed in the packing list will match exactly with the invoice that is sent with your shipment from the country of origin.

Please note that HPP Exhibitions & EHPEA are in no way responsible for the transportation & clearing of your materials, and is not in the position to take any responsibility for these matters.

OBLIGATORY ORDER FORMS (FORM 1 - 5)

IMPORTANT NOTICE

The deadline for sending back all order forms is Friday February 10th, 2023.
Please make sure to fill out all order forms in English and clear capital letters.

SET-UP & BREAK-DOWN BADGES		ORDER FORM 1	OBLIGATORY
		To be returned before: Friday February 10th, 2023	
CONTACT	EMAIL	PHONE	
Mr. Juan Pablo Camacho	juanpablo@hpp.nl	+251-11-6620025	

Company Name:	
Stand number:	
Contact Person:	

Set up & break down badges **WILL NOT** give you access to the hall during exhibition hours!

Please fill out the full name(s) and country to be put on the set up & break badge(s) with **CLEAR CAPITAL LETTERS**. HPP Exhibitions will not be responsible for mistakes in the set up & break-down badges if this form is not clearly readable.

* If you request an exhibitor badge, you will not need a set up and break down badge.

#	COMPANY	FIRST NAME	LAST NAME	COUNTRY
1				
2				
3				
4				
5				
6				
7				
8				
9				
10				
11				
12				

Please note that a badge is required at all times in order to enter the hall!

* If you need more set up & break down badges simply copy this form.

ORDER CONFIRMATION
Please note that, if applicable, sending back this order form automatically means that you agree that the order will be placed and/or invoiced.

EXHIBITOR BADGES		ORDER FORM 2	OBLIGATORY
		To be returned before: Friday February 10th, 2023	
CONTACT	EMAIL	PHONE	
Mr. Juan Pablo Camacho	juanpablo@hpp.nl	+251-11-6620025	

Company Name:	
Stand number:	
Contact Person:	

The exhibitor badge will give you access to the hall during show hours as well as during the build-up & break-down period.

Please fill out the full name(s) and country to be put on the exhibitor badge(s) with **CLEAR CAPITAL LETTERS**. HPP Exhibitions will not be responsible for mistakes in the exhibitor badges if this form is not clearly readable.

*** If you request an exhibitor badge, you will not need a set up and break down badge.**

#	COMPANY	FIRST NAME	LAST NAME	COUNTRY
1				
2				
3				
4				
5				
6				
7				
8				
9				
10				
11				
12				

Please note that a badge is required at all times in order to enter the hall!

* If you need more set-up & break-down badges simply copy this form

ORDER CONFIRMATION
Please note that, if applicable, sending back this order form automatically means that you agree that the order will be placed and/or invoiced.

EXHIBITOR DIRECTORY LISTING		ORDER FORM 3		OBLIGATORY	
		To be returned before: Friday February 10th, 2023			
CONTACT		EMAIL		PHONE	
Mr. Juan Pablo Camacho		juanpablo@hpp.nl		+251-11-6620025	

The official exhibition directory will contain details of the company's profile and products or services of all exhibiting companies. Therefore, please fill out this form with the company information you would like to have published.

Company Name:				Stand number:	
Contact Person:					
Address:					
Zip Code		State:			
City:		Country:			
Phone:					
Email:		Website:			

***HPP Exhibitions is not responsible for any mistakes or wrong information published in the show directory if this order form is not clear or has not been filled out with the required specifications.*

The exhibition directory will also contain a product index. Please indicate by ticking (☑) the activities or services that apply to your company:

- | | |
|---|---|
| <input type="checkbox"/> Air, Road & Sea Transportation & Freight Forwarding | <input type="checkbox"/> Flower Importer / Exporter |
| <input type="checkbox"/> Association | <input type="checkbox"/> Greenhouse Construction, Greenhouse equipment, climate control, internal logistics, irrigation |
| <input type="checkbox"/> Automation, Computerization, Software | <input type="checkbox"/> Machines & Equipment |
| <input type="checkbox"/> Consultancy / Education | <input type="checkbox"/> Potted Plant Breeder / Propagator |
| <input type="checkbox"/> Cooling, Refrigeration & Air Conditioning | <input type="checkbox"/> Potted Plant Grower / Exporter |
| <input type="checkbox"/> Fertilizers, Crop Protection, Peat, Compost, Potting soil & Substrates | <input type="checkbox"/> Potted Plant Importer / Exporter |
| <input type="checkbox"/> Floricultural & Horticultural Products /Services | <input type="checkbox"/> Trade magazines / Books / Publications |
| <input type="checkbox"/> Flower Breeder / Propagator | <input type="checkbox"/> Plant /Crop Protection, Peat, Compost, Fertilizers, Potting soil & Substrates |
| <input type="checkbox"/> Flower bulb Breeder / Exporter | <input type="checkbox"/> Others: _____ |
| <input type="checkbox"/> Flower Grower & Exporter | |

ORDER CONFIRMATION
Please note that, if applicable, sending back this order form automatically means that you agree that the order will be placed and/or invoiced.

FASCIA BOARD TEXT FOR YOUR STAND		ORDER FORM 4	OBLIGATORY
		To be returned before: Friday February 10th, 2023	
CONTACT	EMAIL	PHONE	
Mr. Juan Pablo Camacho	juanpablo@hpp.nl	+251-11-6620025	

Company Name:	
Stand number:	
Contact Person:	

Please write here below in **CLEAR CAPITAL LETTERS** the name of the company as you would like to have it on the fascia of your stand (the text will be all on one line only!):

Name to appear on Fascia text:	
---------------------------------------	--

If you wish, you can also order full colour logos for your fascia's:

Quantity	Description	Price in € per logo	Total Price in €
	Full colour fascia logos (20 cm. x 20 cm.) *	€ 50.00	€

* For bigger logos (only available for on your walls) prices will be quoted upon request.

Please note: If you request a logo or extra text for your fascia board, we will contact you for further details.

ORDER CONFIRMATION
Please note that, if applicable, sending back this order form automatically means that you agree that the order will be placed and/or invoiced.

INDEMNITY FORM		ORDER FORM 5		OBLIGATORY	
		To be returned before: Friday February 10th, 2023			
CONTACT		EMAIL		PHONE	
Mr. Juan Pablo Camacho		juanpablo@hpp.nl		+251-11-6620025	

We herewith agree to indemnify HPP Exhibitions & EHPEA from and against customs levies, fines or any other costs, which may be called upon to be paid to the authorities in Ethiopia on your behalf.

Company Name:	
Contact Person:	
Title/Position:	
Date:	
Signature and company stamp:	

Please note that this indemnity form may only be signed by a legal party of the exhibiting company.

<p align="center">ORDER CONFIRMATION</p> <p>Please note that, if applicable, sending back this order form automatically means that you agree that the order will be placed and/or invoiced.</p>
--

NON OBLIGATORY ORDER FORMS (FORM 6 - 13)

IMPORTANT NOTICE

The deadline for sending back all order forms is Friday February 10th, 2023.
Please make sure to fill out all order forms in English and clear capital letters.

ORDER CONFIRMATION

Please note that, if applicable, sending back this order form automatically means that you agree that the order will be placed and/or invoiced.

ADVERTISING		ORDER FORM 6 NON-OBLIGATORY	
To be returned before: Friday February 10th, 2023			
CONTACT	EMAIL	PHONE	
Mr. Juan Pablo Camacho	juanpablo@hpp.nl	+251-11-6620025	

Company Name:	
Stand number:	
Contact Person:	

As an exhibitor you can place an advertisement in the official exhibition directory. To advertise in it, please complete this form. Size of the official exhibition directory will be A5 standard size (150 mm. in width x 210 mm. in height). Please make sure you have an extra 3mm trim space all around.



HALF PAGE



FULL PAGE

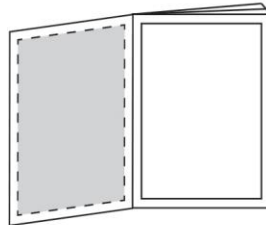

INNER FRONT COVER

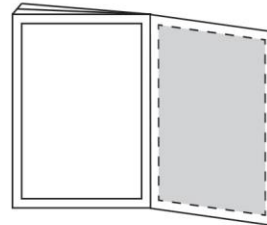

INNER BACK COVER

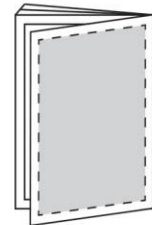

BACK COVER

All advertisements must be submitted according to the following technical specifications

- Format** : .TIFF, .PDF, JPG
- Resolution** : 300 dpi (minimum)
- Color Mode** : CMYK
- Full Page** : 150mm width x 210mm height
- Half Page** : 150mm width x 105mm height
- Bleed** : 3mm all around

CODE	Description	Quantity	Unit price in €	Total Price in €
AD001	Half Page (Black and White)		€ 225.00	
AD002	Half Page (Full Color)		€ 450.00	
AD003	Full Page (Black and White)		€ 350.00	
AD004	Full Page (Full Color)		€ 700.00	
AD005	Inner Front Cover		€ 950.00	
AD006	Inner Back Cover		€ 950.00	
AD007	Back Cover		€ 1,250.00	
			Total amount in €	

WEBSITE LINK		ORDER FORM 7 NON-OBLIGATORY To be returned before: Friday February 10th, 2023	
CONTACT	EMAIL	PHONE	
Mr. Juan Pablo Camacho	juanpablo@hpp.nl	+251-11-6620025	

Company Name:	
Stand number:	
Contact Person:	

HPP Exhibitions is pleased to offer you, free of charge, a link from the HORTIFLORA EXPO 2023 website to your own website.

Visitors of the HORTIFLORA EXPO 2023 website, www.hortifloraexpo.com, can click on your company name in the list of exhibitors and will be directly linked to your website.

This link provides the visitor an opportunity to get acquainted with your company and you line of products.

If you would like to have a link to your own website, please fill out this form.

YES, I would like to have my website linked on www.hortifloraexpo.com

Website:	www.
-----------------	------

ORDER CONFIRMATION
Please note that, if applicable, sending back this order form automatically means that you agree that the order will be placed and/or invoiced.

CUSTOMER INVITATION LINK		ORDER FORM 8	NON-OBLIGATORY
		To be returned before: Friday February 10th, 2023	
CONTACT	EMAIL	PHONE	
Mr. Juan Pablo Camacho	juanpablo@hpp.nl	+251-11-6620025	

Company Name:	
Stand number:	
Contact Person:	
Email Address:	<i>(Where the cc email of the registration will be sent to, 1 email address possible only)</i>

You can order free of charge your Personalized Customer Invitation Link, which you can forward by email to any of your customers who you would like to invite to HORTIFLORA EXPO 2023.

By clicking on this link, the customer will go direct to the online registration form which must be filled out and sent back. You will receive a cc on the email that confirms you customer filled out the registration form online.

Please note: *Attending the Expo is open to trade visitors only and is subject to our admission policy as outlined in paragraph 1.7. in this manual, each registration will be reviewed and answered directly to the registrant! Registrants also need to be 18 years or older to attend the Expo.*

YES, I would like to receive my personalized customer invitation link

If you have any questions in regards to the personalized customer invitation links you can contact Mr. Jasper van Dijk directly at: jasper@hpp.nl

ORDER CONFIRMATION
Please note that, if applicable, sending back this order form automatically means that you agree that the order will be placed and/or invoiced.

ELECTRICAL OUTLETS		ORDER FORM 9	NON-OBLIGATORY
		To be returned before: Friday February 10th, 2023	
CONTACT	EMAIL	PHONE	
Mr. Juan Pablo Camacho	juanpablo@hpp.nl	+251-11-6620025	

Company Name:	
Stand number:	
Contact Person:	

Please note: If you ordered the Stand construction package through your contract or through order form 4 of this manual, 1 outlet is already included on you package. Floorspace only stands do not have any electrical outlets included!

Ethiopia's electrical current is 220/50 (Volts/Hz). The outlet includes electrical connection with capacity of 1000 watts. Plug types are Type C/F

YES, I would like to order (extra) outlets.

Quantity	Description	Price in €	Total Price in €
	240/50 (Volts/Hz) outlet	€ 52.50	€







ORDER CONFIRMATION
 Please note that, if applicable, sending back this order form automatically means that you agree that the order will be placed and/or invoiced.

FURNISHINGS		ORDER FORM 10A NON-OBLIGATORY	
		To be returned before: Friday February 10th, 2023	
CONTACT	EMAIL	PHONE	
Mr. Juan Pablo Camacho	juanpablo@hpp.nl	+251-11-6620025	

Company Name:	
Stand number:	
Contact Person:	

If you wish to rent any of these additional furniture or appliances for your stand, please fill out the form below:

Image	Description	Code	QTY	Unit price in €	Total Price in €
	Additional low table + 3 low chairs	TC-01		€ 150.00	€
	Bar table + 3 bar stools (black)	TC-02		€ 200.00	€
	Bar table + 3 bar stools (white)	TC-03		€ 200.00	€
	Round table Ø 70cm, 1 78cm	TC-04		€ 200.00	€
Total amount					€

Please note: Prices are excluding VAT (if applicable).

ORDER CONFIRMATION

Please note that, if applicable, sending back this order form automatically means that you agree that the order will be placed and/or invoiced.

FURNISHINGS		ORDER FORM 10B NON-OBLIGATORY To be returned before: Friday February 10th, 2023	
CONTACT	EMAIL	PHONE	
Mr. Juan Pablo Camacho	juanpablo@hpp.nl	+251-11-6620025	

Company Name:	
Stand number:	
Contact Person:	

If you wish to rent any of these additional furniture or appliances for your stand, please fill out the form bellow:

Image	Description	Code	QTY	Unit price in €	Total Price in €
	Lockable cabinet	LC-01		€ 150.00	€
	Stand built-in shelf	S-04		€ 75.00	€
	Refrigerator (100cm height)	RF-01		€ 150.00	€
	Show-case rack / Brochure holder	SR-01		€ 75.00	€
Total amount					€

Please note: Prices are excluding VAT (if applicable).



ORDER CONFIRMATION

Please note that, if applicable, sending back this order form automatically means that you agree that the order will be placed and/or invoiced.

AUDIOVISUALS & SUPPLIES		ORDER FORM 11		NON-OBLIGATORY	
		To be returned before: Friday February 10th, 2023			
CONTACT		EMAIL		PHONE	
Mr. Juan Pablo Camacho		juanpablo@hpp.nl		+251-11-6620025	

Company Name:	
Stand number:	
Contact Person:	

If you wish to rent any of these appliances for your stand, please fill out the form bellow:

Image	Description	Quantity	Unit price in €	Total Price in €
	37" LCD TV		€ 600.00	€
	DVD Player		€ 125.00	€
Total amount				€

Please note: Prices are excluding VAT (if applicable).

ORDER CONFIRMATION
Please note that, if applicable, sending back this order form automatically means that you agree that the order will be placed and/or invoiced.

STORAGE IN YOUR STAND		ORDER FORM 12	NON-OBLIGATORY
		To be returned before: Friday February 10th, 2023	
CONTACT	EMAIL	PHONE	
Mr. Juan Pablo Camacho	juanpablo@hpp.nl	+251-11-6620025	

Company Name:	
Stand number:	
Contact Person:	



	Description	Price in € per m ²	Total Price in €
<input type="checkbox"/>	Storage 1m x 1m with lockable door	€ 120.00	€
<input type="checkbox"/>	Storage 2m x 1m with lockable door	€ 170.00	€
Total amount			€

Please draw your stand to scale and indicate where you would like to have your storage:

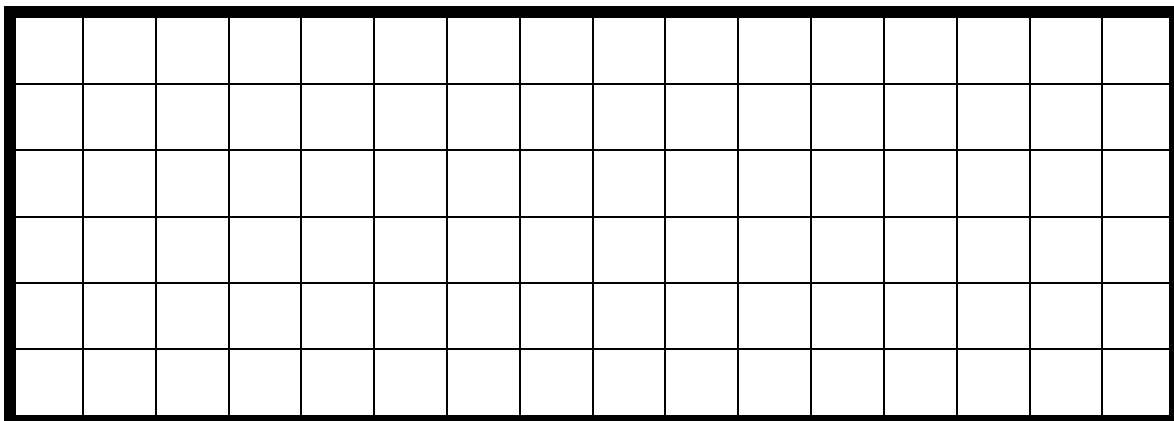

1m²

Please note: Prices are excluding VAT (if applicable).

ORDER CONFIRMATION

Please note that, if applicable, sending back this order form automatically means that you agree that the order will be placed and/or invoiced.

FLOWER DESIGNING		ORDER FORM 13 NON-OBLIGATORY To be returned before: Friday February 10th, 2023	
CONTACT	EMAIL	PHONE	
Mr. Juan Pablo Camacho	juanpablo@hpp.nl	+251-11-6620025	

Company Name:	
Stand number:	
Contact Person:	

You can request professional flower designing for your stand on HORTIFLORA EXPO 2023. HPP offers the services of its professional team of designers as an extra way to highlight your participation.

The service includes: rental of wooden pillar (on the colour of choice), vase rental, flower designing, daily maintenance of the flower design and disposal of the flowers at the end of the exhibition.

YES, I would like be contacted for special flower designing needs and receive a quote.

ORDER CONFIRMATION

Please note that, if applicable, sending back this order form automatically means that you agree that the order will be placed and/or invoiced.