



HORTIFLORA

International Floriculture & Horticulture Trade Fair

**9TH BIENNIAL INTERNATIONAL TRADE EXPO FOR THE
ETHIOPIAN HORTICULTURE & FLORICULTURE INDUSTRY**

**TUESDAY APRIL 1 - THURSDAY APRIL 3 • 2025
MILLENNIUM HALL • ADDIS ABABA • ETHIOPIA**

EXHIBITOR MANUAL

Updated: 20/DEC/2025 11:52 AM

Organized and managed by:



In cooperation with:



EHPEA
SUPPORT - CONNECT - EXCHANGE

INDEX

	Page
1. GENERAL INFORMATION	
1.1 VENUE ADDRESS	3
1.2 IMPORTANT TIMES & DATES	3
1.3 EXHIBITION BADGES.....	3
1.4 EXHIBITION DIRECTORY	4
1.5 ADDITIONAL PROMOTION TOOLS.....	4
1.6 OTHER SERVICES	4
1.7 VISITOR ADMISSION POLICY	4
1.8 FLOWER DESIGNING	4
 2. STAND CONSTRUCTION, FURNISHINGS & OTHERS	
2.1 STAND CONSTRUCTION PACKAGE DETAILS	5
2.2 RENTAL OF FURNISHINGS & OTHERS.....	6
2.3 STAND CLEANING.....	6
2.4 INDEMNITY FORM.....	6
2.5 INSURANCE	6
 3. CUSTOMS CLEARANCE	6
 4. OBLIGATORY ORDER FORMS	
ORDER FORM 1 OBLIGATORY SET UP & BREAK DOWN BADGES	8
ORDER FORM 2 OBLIGATORY EXHIBITOR BADGES.....	9
ORDER FORM 3 OBLIGATORY EXHIBITOR DIRECTORY LISTING	10
ORDER FORM 4 OBLIGATORY INDEMNITY FORM	11
 5. NON-OBLIGATORY ORDER FORMS	
ORDER FORM 5 STAND CONSTRUCTION PACKAGE	13
ORDER FORM 6 FASCIA BOARD TEXT FOR YOUR STAND.....	14
ORDER FORM 7 ADVERTISING	15
ORDER FORM 8 WEBSITE LINK	16
ORDER FORM 9 CUSTOMER INVITATION LINK	17
ORDER FORM 10 ELECTRICAL OUTLETS	18
ORDER FORM 11A FURNISHINGS	19
ORDER FORM 11B FURNISHINGS	20
ORDER FORM 12 AUDIOVISUALS & SUPPLIES	21
ORDER FORM 13 STORAGE IN YOUR STAND	22
ORDER FORM 14 FLOWER DESIGNING	23

1. GENERAL INFORMATION

1.1. VENUE ADDRESS

Millennium Hall
 Bole, Addis Ababa
 Ethiopia

Millennium hall is one of the most desirable trade fair venues in northeast Africa. It spreads across 87,000 sqm of landscape with an indoor space of 19,000sqm offering a huge expo hall stretched up to 5000sqm, 4 conference rooms, parking facilities, round the clock security. The hall is very close and easily accessible from the Addis Ababa International Airport and there are multiple four and five star rated according to UNWTO standard hotels found nearby made it to be one of the best venues for conducting regional and international exhibitions/trade fairs, conferences, seminars, private functions & events, etc in Addis Ababa.

1.2. IMPORTANT TIMES & DATES

- **SET UP (BUILD UP).**

Sunday March 30	08:00 a.m. - 06:00 p.m.
Monday March 31	08:00 a.m. - 06:00 p.m.

All exhibits must be set up by 06:00 p.m. on Monday evening, March 31.
- **BREAK DOWN (MOVE OUT).**

Thursday April 3	04:00 p.m. - 10:00 p.m.
------------------	-------------------------

All exhibits must be cleared by 10:00 p.m. on Thursday evening, April 3.
- **HOURS TO REFRESH AND/OR REDESIGN YOUR FLOWERS.**

Tuesday April 1	09:00 a.m. - 10:00 a.m.
Wednesday April 2	09:00 a.m. - 10:00 a.m.
Thursday April 3	09:00 a.m. - 10:00 a.m.
- **EXHIBITION DAY TO DAY PROGRAMME**

Tuesday April 1	10:00 a.m. - 10:30 a.m. <i>Official opening ceremony</i> 10:30 a.m.- 06:00 p.m. <i>Exhibition hours for trade visitors only.</i>
Wednesday April 2	10:00 a.m. - 06:00 p.m. <i>Exhibition hours for trade visitors only.</i>
Thursday April 3	10:00 a.m. - 04:00 p.m. <i>Exhibition hours for trade visitors only.</i>

1.3. EXHIBITION BADGES

- **SET UP & BREAK DOWN BADGES.**
 The set up & break down badge is a personal identification and it will give you access to the hall ONLY during set up and break down hours. It WILL NOT give access during exhibition hours.

Every exhibiting company will receive the required number of set up & break down badges which can be requested through OBLIGATORY ORDER FORM 1 on page 8. Exhibitors are required to send this form back before Thursday February 27th, 2025.

Please note: All badges are personal, non-transferable and valid only for people over 18 years old. Random ID checks will be executed therefore please carry a valid ID at all times.

Badges can be picked up at the registration desk during the following hours as well as during show hours:

Sunday March 30	08:00 a.m. - 06:00 p.m.
Monday March 31	08:00 a.m. - 06:00 p.m.
Thursday April 3	08:00 a.m. - 04:00 p.m.

Please note: If you request an exhibitor badge, you will not need an extra set up and break down badge.

- **EXHIBITOR BADGES.**

The exhibitor badge is your personal identification and it will give you access to the exhibition floor at all time. Every exhibiting company will receive the number of exhibitor badges requested through OBLIGATORY ORDER FORM 2 on page 9. Exhibitors are required to send this form back before Thursday February 27th, 2025.

Badges can be picked up at the registration desk during the following hours:

Sunday March 30	08:00 a.m. - 06:00 p.m.
Monday March 31	08:00 a.m. - 06:00 p.m.
Tuesday April 1	09:00 a.m. - 06:00 p.m.
Wednesday April 2	08:00 a.m. - 06:00 p.m.
Thursday April 3	08:00 a.m. - 04:00 p.m.

Please note: All badges are personal, non-transferable and only for people over 18 years old. Everyone must carry a valid ID at all times, as the name on the badge will need to match with the name of your ID.

1.4. EXHIBITION DIRECTORY

- **EXHIBITION DIRECTORY LISTING.**

For HORTIFLORA 2025 an exhibition directory will be published and distributed among trade visitors. It will contain company name, address and contact details of your company in alphabetical order. The English directory is a practical resource for visitors and is, above all, an intensively used reference book. Inclusion in this official directory is free and can increase exposure for your participation in the fair during and after the event.

Your company will also be included in the product index in alphabetical order.

Please fill out OBLIGATORY ORDER FORM 3 on page 10 of this manual. Exhibitors are required to send this form back before Thursday February 27th, 2025.

- **ADVERTISING.**

An additional way to highlight your presence at HORTIFLORA 2025 is to take an advertisement in the exhibition directory. This is optional.

Please fill out NON-OBLIGATORY ORDER FORM 7 on page 15 if you want to publish an advertisement in the exhibition directory. Exhibitors are required to send this form and the artwork back to our offices before Thursday February 27th, 2025.

1.5. ADDITIONAL PROMOTION TOOLS

- **WEBSITE LINK.**

As an extra tool of advertising, HPP Worldwide offers you the possibility to have a website link to your own company website. Visitors to the HORTIFLORA 2025 website can click on your company name in the exhibitor list and will be directly linked to your website/page (www.hortifloraexpo.com). The link provides visitors an opportunity to get acquainted with your company and your line of products and/or services given beforehand.

If you would like to have a website link, please fill out NON-OBLIGATORY ORDER FORM 8 on page 16. Exhibitors are required to send this form back before Thursday February 27th, 2025.

- **CUSTOMER INVITATION LINK.**

You can order*, free of charge, your personalized customer invitation link, which you can forward to any of your customers who you would like to invite to HORTIFLORA 2025.

For this option, please fill out the NON-OBLIGATORY ORDER FORM 9 on page 17.

**subject to our visitor admission policy as outlined in paragraph 1.7.*

1.6. OTHER SERVICES

For special stand designs, background printing and decoration of your stand please contact:

HPP Worldwide:

Contact : Mr. Juan Pablo Camacho

Email : juanpablo@hpp.nl

1.7. VISITOR ADMISSION POLICY

HORTIFLORA 2025 is a business trade exhibition exclusively reserved for qualified visitors, namely growers and buyers of flowers, vegetables, fruits and herbs can attend free of charge. Civil servants and suppliers to the trade can also attend free of charge. Qualified visitors can enter the exhibition free of charge.

Engaging in unsolicited vending activities is strictly prohibited during the exhibition.

Individuals unrelated to floriculture and horticulture trade or the general public are considered non-qualified and are not permitted to attend the exhibition under any circumstances.

To attend the exhibition, all attendees must be 18 years of age or older. Children and babies are not allowed to attend, and no exceptions will be made.

For further questions regarding visitor registration, you can contact Mr. Jasper van Dijk at: jasper@hpp.nl

1.8. FLOWER DESIGNING

You can request professional flower designing for your stand on HORTIFLORA 2025. HPP offers the services of its professional team of designers as an extra way to highlight your participation. The service includes: rental of wooden pillar on the colour of choice, vase rental, flower designing, daily maintenance and disposal at the end of the exhibition.

To request flower designs, please fill out NON-OBLIGATORY ORDER FORM 14 on page 23.

2. STAND CONSTRUCTION, FURNISHINGS & OTHERS

2.1. STAND CONSTRUCTION PACKAGE DETAILS

Exhibitors, who are wishing to do so, can order one of the rental stand construction options offered by the organizer via NON-OBLIGATORY ORDER FORM 5 on page 13 of this manual. The stand construction package facilitates exhibitors and offers various options to particularize their presentations. The stand is built by professional stand builders.

The Stand Construction Package includes:

- Back- and side system walls (white panels, 2.50 meters high)
- One, two, three or four fascia boards (depending on the location of the stand), which displays the company name.
- **CONTRACT DOES NOT INCLUDE CARPET**
- 1 standard low table + 3 standard chairs per stand;
- 1 spotlight per every 3 m².

Rental price per m² is € 55.00 for the full package. In case you have already chosen for this stand construction package through your contract, please fill out NON-OBLIGATORY ORDER FORM 6 on page 14 of this manual. Exhibitors are required to send back this form before Friday February 25th

- Please take into account that the back and side walls of your stand are hard white panels of 1 meter width and 2,50 meters height.
- It is forbidden to damage, drill, paint, and weld or modify in any way the hall floor. You will be charged for any repairs or renewals.
- It is not allowed to paint, drill, hammer, stick non removal materials hang heavy structures or damage in any other way the panels and/or fascia boards of your stand. You will be charged for any repairs or renewals.

Example of Modular Octanorm Shell Scheme System Construction

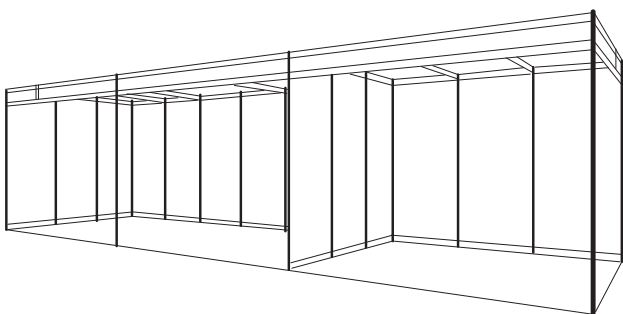

Shell Scheme Dimensions of the Octanorm Stand Construction

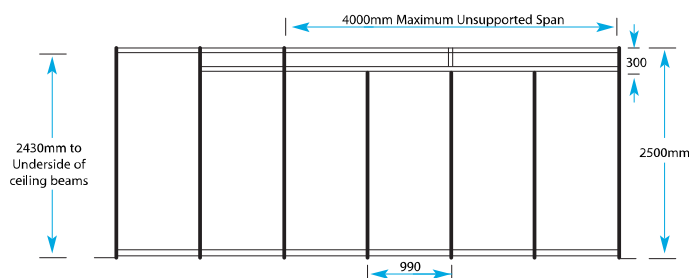

Panel Dimensions of the Octanorm Stand Construction

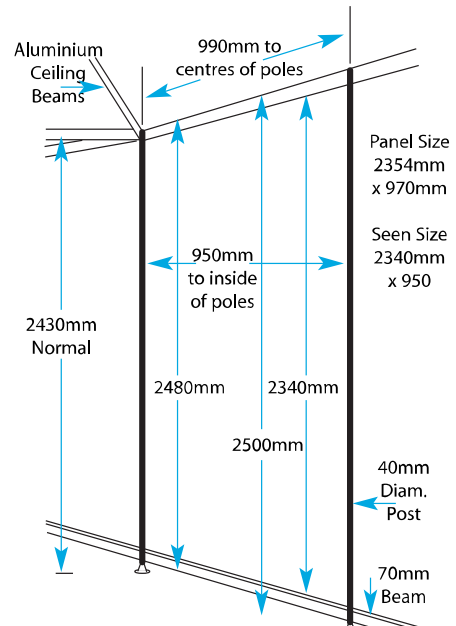

2.2. RENTAL OF FURNISHINGS & OTHERS

ELECTRICAL OUTLET.

If you would like to order outlets for your stand please fill out NON-OBLIGATORY ORDER FORM 10 on page 18. Exhibitors are required to send this form back before Thursday February 27th, 2025.

TABLES, CHAIRS & FURNISHING.

We have different additional options of tables, chairs and furnishings to choose from, if you want to order any additional or design furniture or refrigerators, please fill out NON-OBLIGATORY ORDER FORM 11A on page 19 or NON-OBLIGATORY ORDER FORM 11B on page 20. Exhibitors are required to send these forms back before Thursday February 27th, 2025.

AUDIOVISUALS & SUPPLIES.

Additional equipment such as TV's will also be available upon request. If you want to order any of these options, please fill out NON-OBLIGATORY ORDER FORM 12 on page 21. Exhibitors are required to send this form back before Thursday February 27th, 2025.

2.3. STAND CLEANING

The exhibition hall and stands will be cleaned each day before the show opens. Please place your waste basket outside your stand at the end of each day. Cleaners will not be permitted to clean any stand without the explicit request of the exhibitor.

2.4. INDEMNITY FORM

Exhibitors are required to sign the indemnity form. Please fill out OBLIGATORY ORDER FORM 4 on page 11 or. Exhibitors are required to send this form back before Thursday February 27th, 2025.

2.5. INSURANCE

HPP Worldwide & EHPEA are not responsible for any loss or damages to your exhibition material related to this exhibition. We recommend you to take insurance for your exhibition materials.

3. CUSTOMS CLEARANCE

For import and customs clearance of your exhibition goods, find herewith a possible customs clearance company, which can be contacted in case you need assistance for customs clearance matters. HPP Worldwide & EHPEA will however not assume any responsibility of any kind of the clearance of shipments.:

BELLA LOGISTICS contact details:

Address: Akaki Kality, Woreda-06
In front of Kality Customs Compound,
Kaleb Building First floor, Office No.119
Addis Ababa, Ethiopia
Phone: +251-911-451057
Phone: +251-930-288759
E-mail: bellalogistics.et@gmail.com

Services:

- Freight Forwarding-coordinating and organizing the movement of shipments on behalf of a shipper by liaising with carriers via air, marine, rail or highway.
- Customs Clearance-process of declaring goods entering or leaving a country to Customs authorities with detailed information about the shipment, including its value, origin, destination, and contents.
- Project Logistics-involves planning, organizing, managing, processing, and controlling the complete flow of goods with characteristics such as large, heavy, bulky, out-of-gauge, unusually shaped, high-value and critical items.
- Packing & Moving-making relocation procedure as stress-free as possible to clients.
- Door to Door Delivery-delivery saves clients cost and time, avoiding risk of loss or damage of product and facilitating logistics management.
- Warehousing & Distribution- Warehousing deals with the efficient storage and handling of goods, while distribution ensures these goods reach consumers.
- Transportation services integrated via air, marine, rail, or highway.

IMPORTANT WARNING!

In order to have your exhibition goods custom cleared into Ethiopia on time, we urge your company to send a detailed packing list and invoice to the contact person mentioned above, ASAP. Make sure that the goods listed in the packing list will match exactly with the invoice that is sent with your shipment from the country of origin.

Please note: HPP Worldwide & EHPEA will not and cannot take any responsibility in the clearance of your exhibition materials into the country, since HPP & EHPEA have no involvement in any importation matters of any exhibition goods of any exhibitor of HORTIFLORA 2025.

OBLIGATORY ORDER FORMS

(FORM 1 - 5)

IMPORTANT NOTICE

The deadline for sending back all order forms is Thursday February 27th, 2025.
Please make sure to fill out all order forms in English and clear capital letters.

SET-UP & BREAK-DOWN BADGES		ORDER FORM 1	OBLIGATORY
		To be returned before: Thursday February 27th, 2025.	
CONTACT	EMAIL	PHONE	
Mr. Juan Pablo Camacho	juanpablo@hpp.nl	+251-11-6620025	

Company Name:	
Stand number:	
Contact Person:	

Set up & break down badges **WILL NOT** give you access to the hall during exhibition hours!

Please fill out the full name(s) and country to be put on the set up & break badge(s) with **CLEAR CAPITAL LETTERS**. HPP Worldwide will not be responsible for mistakes in the set up & break-down badges if this form is not clearly readable.

* If you request an exhibitor badge, you will not need a set up and break down badge.

#	COMPANY	FIRST NAME	LAST NAME	COUNTRY
1				
2				
3				
4				
5				
6				
7				
8				
9				
10				
11				
12				

Please note that a badge is required at all times in order to enter the hall!

* If you need more set up & break down badges simply copy this form.

ORDER CONFIRMATION
Please note that, if applicable, sending back this order form automatically means that you agree that the order will be placed and/or invoiced.

EXHIBITOR BADGES		ORDER FORM 2	OBLIGATORY
		To be returned before: Thursday February 27th, 2025.	
CONTACT	EMAIL	PHONE	
Mr. Juan Pablo Camacho	juanpablo@hpp.nl	+251-11-6620025	

Company Name:	
Stand number:	
Contact Person:	

The exhibitor badge will give you access to the hall during show hours as well as during the build-up & break-down period.

Please fill out the full name(s) and country to be put on the exhibitor badge(s) with **CLEAR CAPITAL LETTERS**. HPP Worldwide will not be responsible for mistakes in the exhibitor badges if this form is not clearly readable.

*** If you request an exhibitor badge, you will not need a set up and break down badge.**

#	COMPANY	FIRST NAME	LAST NAME	COUNTRY
1				
2				
3				
4				
5				
6				
7				
8				
9				
10				
11				
12				

Please note that a badge is required at all times in order to enter the hall!

* If you need more set-up & break-down badges simply copy this form

ORDER CONFIRMATION
Please note that, if applicable, sending back this order form automatically means that you agree that the order will be placed and/or invoiced.

EXHIBITOR DIRECTORY LISTING		ORDER FORM 3		OBLIGATORY	
		To be returned before: Thursday February 27th, 2025.			
CONTACT		EMAIL		PHONE	
Mr. Juan Pablo Camacho		juanpablo@hpp.nl		+251-11-6620025	

The official exhibition directory will contain details of the company's profile and products or services of all exhibiting companies. Therefore, please fill out this form with the company information you would like to have published.

Company Name:		Stand number:	
Contact Person:			
Address:			
Zip Code		State:	
City:		Country:	
Phone:			
Email:		Website:	

HPP Worldwide is not responsible for any mistakes or wrong information published in the show directory if this order form is not clear or has not been filled out with the required specifications.

The exhibition directory will also contain a product index. Please indicate by ticking (☑) the activities or services that apply to your company:

- | | |
|---|--|
| <input type="checkbox"/> Air, Road & Sea Transportation & Freight Forwarding
<input type="checkbox"/> Association
<input type="checkbox"/> Automation, Computerization, Software
<input type="checkbox"/> Consultancy / Education
<input type="checkbox"/> Cooling, Refrigeration & Air Conditioning
<input type="checkbox"/> Fertilizers, Crop Protection, Peat, Compost, Potting soil & Substrates
<input type="checkbox"/> Floricultural & Horticultural Products / Services
<input type="checkbox"/> Breeder / Propagator
<input type="checkbox"/> Bulb Breeder / Exporter | <input type="checkbox"/> Grower & Exporter (Flowers)
<input type="checkbox"/> Grower & Exporter (Fruits, Herbs & Vegetables)
<input type="checkbox"/> Importer / Exporter
<input type="checkbox"/> Greenhouse Construction, Greenhouse equipment, climate control, internal logistics, irrigation
<input type="checkbox"/> Machines & Equipment
<input type="checkbox"/> Trade magazines / Books / Publications
<input type="checkbox"/> Plant /Crop Protection, Peat, Compost, Fertilizers, Potting soil & Substrates
<input type="checkbox"/> Others: |
|---|--|

ORDER CONFIRMATION
Please note that, if applicable, sending back this order form automatically means that you agree that the order will be placed and/or invoiced.

INDEMNITY FORM		ORDER FORM 4		OBLIGATORY	
		To be returned before: Thursday February 27th, 2025.			
CONTACT		EMAIL		PHONE	
Mr. Juan Pablo Camacho		juanpablo@hpp.nl		+251-11-6620025	

We herewith agree to indemnify HPP Worldwide & EHPEA from and against customs levies, fines or any other costs, which may be called upon to be paid to the authorities in Ethiopia on your behalf.

Company Name:	
Contact Person:	
Title/Position:	
Date:	
Signature and company stamp:	

Please note that this indemnity form may only be signed by a legal party of the exhibiting company.

ORDER CONFIRMATION
Please note that, if applicable, sending back this order form automatically means that you agree that the order will be placed and/or invoiced.

NON OBLIGATORY ORDER FORMS

(FORM 5 - 14)

IMPORTANT NOTICE

The deadline for sending back all order forms is Thursday February 27th, 2025.
Please make sure to fill out all order forms in English and clear capital letters.

ORDER CONFIRMATION

Please note that, if applicable, sending back this order form automatically means that you agree that the order will be placed and/or invoiced.

STAND CONSTRUCTION PACKAGE		ORDER FORM 5		NON-OBLIGATORY	
		To be returned before: Thursday February 27th, 2025.			
CONTACT		EMAIL		PHONE	
Mr. Juan Pablo Camacho		juanpablo@hpp.nl		+251-11-6620025	
				FAX	

Company Name:	
Stand number:	
Contact Person:	

Please note: This form only needs to be filled out if you have not ordered the stand construction package through your contract but would still like to do so.

	Stand construction package	Stand size in m ²	Price in € per m ²	Total Price in €
<input type="checkbox"/>	Includes: back- and side walls, fascia board with company name, 1 table, 3 chairs, 1 spotlight per 3 m ² , daily stand cleaning.		€ 55.00	

*If you choose the Stand Construction package, please fill out form 6 on the next page of this manual.

FASCIA BOARD TEXT FOR YOUR STAND		ORDER FORM 6	NON-OBLIGATORY
		To be returned before: Thursday February 27th, 2025.	
CONTACT	EMAIL	PHONE	
Mr. Juan Pablo Camacho	juanpablo@hpp.nl	+251-11-6620025	

Company Name:	
Stand number:	
Contact Person:	

Please write here below in **CLEAR CAPITAL LETTERS** the name of the company as you would like to have it on the fascia of your stand (the text will be all on one line only!):

Name to appear on Fascia text:	
---------------------------------------	--

If you wish, you can also order full colour logos for your fascia's:

Quantity	Description	Price in € per logo	Total Price in €
	Full colour fascia logos (20 cm. x 20 cm.) *	€ 45.00	€

* For bigger logos (only available for on your walls) prices will be quoted upon request.

Please note: If you request a logo or extra text for your fascia board, we will contact you for further details.

ORDER CONFIRMATION
Please note that, if applicable, sending back this order form automatically means that you agree that the order will be placed and/or invoiced.

ADVERTISING		ORDER FORM 7 NON-OBLIGATORY	
		To be returned before: Thursday February 27th, 2025.	
CONTACT	EMAIL	PHONE	
Mr. Juan Pablo Camacho	juanpablo@hpp.nl	+251-11-6620025	

Company Name:	
Stand number:	
Contact Person:	

As an exhibitor you can place an advertisement in the official exhibition directory. To advertise in it, please complete this form. Size of the official exhibition directory will be A5 standard size (150 mm. in width x 210 mm. in height). Please make sure you have an extra 3mm trim space all around.

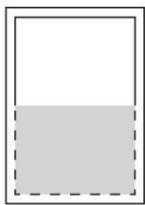

HALF PAGE



FULL PAGE

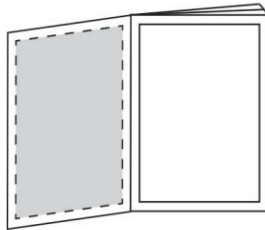

INNER FRONT COVER

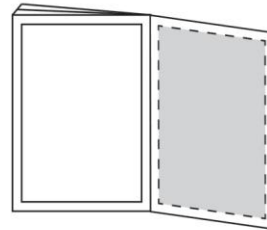

INNER BACK COVER

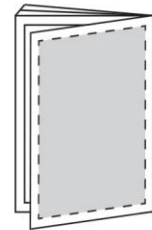

BACK COVER

All advertisements must be submitted according to the following technical specifications

- Format** : .TIFF, .PDF, JPG
- Resolution** : 300 dpi (minimum)
- Color Mode** : CMYK
- Full Page** : 150mm width x 210mm height
- Half Page** : 150mm width x 105mm height
- Bleed** : 3mm all around

CODE	Description	Quantity	Unit price in €	Total Price in €
AD001	Half Page (Black and White)		€ 225.00	
AD002	Half Page (Full Color)		€ 450.00	
AD003	Full Page (Black and White)		€ 350.00	
AD004	Full Page (Full Color)		€ 700.00	
AD005	Inner Front Cover		€ 950.00	
AD006	Inner Back Cover		€ 950.00	
AD007	Back Cover		€ 1,250.00	
			Total amount in €	

ORDER CONFIRMATION

Please note that, if applicable, sending back this order form automatically means that you agree that the order will be placed and/or invoiced.

WEBSITE LINK		ORDER FORM 8 NON-OBLIGATORY	
		To be returned before: Thursday February 27th, 2025.	
CONTACT	EMAIL	PHONE	
Mr. Juan Pablo Camacho	juanpablo@hpp.nl	+251-11-6620025	

Company Name:	
Stand number:	
Contact Person:	

HPP Worldwide is pleased to offer you, free of charge, a link from the HORTIFLORA 2025 website to your own website.

Visitors of the HORTIFLORA 2025 website, www.hortifloraexpo.com, can click on your company name in the list of exhibitors and will be directly linked to your website.

This link provides the visitor an opportunity to get acquainted with your company and you line of products.

If you would like to have a link to your own website, please fill out this form.

YES, I would like to have my website linked on www.hortifloraexpo.com

Website:	www.
-----------------	------

ORDER CONFIRMATION
Please note that, if applicable, sending back this order form automatically means that you agree that the order will be placed and/or invoiced.

CUSTOMER INVITATION LINK		ORDER FORM 9	NON-OBLIGATORY
		To be returned before: Thursday February 27th, 2025.	
CONTACT	EMAIL	PHONE	
Mr. Juan Pablo Camacho	juanpablo@hpp.nl	+251-11-6620025	

Company Name:	
Stand number:	
Contact Person:	
Email Address:	

(Where the cc email of the registration will be sent to, 1 email address possible only)

You can order free of charge your Personalized Customer Invitation Link, which you can forward by email to any of your customers who you would like to invite to HORTIFLORA 2025.

By clicking on this link, the customer will go direct to the online registration form which must be filled out and sent back. You will receive a cc on the email that confirms you customer filled out the registration form online.

Please note: *Attending the Expo is open to trade visitors only and is subject to our admission policy as outlined in paragraph 1.7. in this manual, each registration will be reviewed and answered directly to the registrant! Registrants also need to be 18 years or older to attend the Expo.*

YES, I would like to receive my personalized customer invitation link

If you have any questions in regards to the personalized customer invitation links you can contact Mr. Jasper van Dijk directly at: jasper@hpp.nl

ORDER CONFIRMATION
Please note that, if applicable, sending back this order form automatically means that you agree that the order will be placed and/or invoiced.

ELECTRICAL OUTLETS		ORDER FORM 10	NON-OBLIGATORY
		To be returned before: Thursday February 27th, 2025.	
CONTACT	EMAIL	PHONE	
Mr. Juan Pablo Camacho	juanpablo@hpp.nl	+251-11-6620025	

Company Name:	
Stand number:	
Contact Person:	

Please note: If you ordered the Stand construction package through your contract or through order form 5 of this manual, 1 outlet is already included on you package. Floorspace only stands do not have any electrical outlets included!

Ethiopia's electrical current is 220/50 (Volts/Hz). The outlet includes electrical connection with capacity of 1000 watts. Plug types are Type C/F

YES, I would like to order (extra) outlets.

Quantity	Description	Price in €	Total Price in €
	240/50 (Volts/Hz) outlet	€ 47.50	€







ORDER CONFIRMATION
 Please note that, if applicable, sending back this order form automatically means that you agree that the order will be placed and/or invoiced.

FURNISHINGS		ORDER FORM 11A NON-OBLIGATORY	
		To be returned before: Thursday February 27th, 2025.	
CONTACT	EMAIL	PHONE	
Mr. Juan Pablo Camacho	juanpablo@hpp.nl	+251-11-6620025	

Company Name:	
Stand number:	
Contact Person:	

If you wish to rent any of these additional furniture or appliances for your stand, please fill out the form below:

Image	Description	Code	QTY	Unit price in €	Total Price in €
	Additional meeting table + 3 low chairs	TC-01		€ 150.00	€
	Bar table + 3 bar stools (black)	TC-02		€ 195.00	€
	Bar table + 3 bar stools (white)	TC-03		€ 195.00	€
	Bar table + 3 plastic bar stools.	TC-04		€ 175.00	€
Total amount					€

Please note: Prices are excluding VAT (if applicable).

ORDER CONFIRMATION

Please note that, if applicable, sending back this order form automatically means that you agree that the order will be placed and/or invoiced.

FURNISHINGS		ORDER FORM 11B NON-OBLIGATORY	
		To be returned before: Thursday February 27th, 2025.	
CONTACT	EMAIL	PHONE	
Mr. Juan Pablo Camacho	juanpablo@hpp.nl	+251-11-6620025	

Company Name:	
Stand number:	
Contact Person:	

If you wish to rent any of these additional furniture or appliances for your stand, please fill out the form bellow:

Image	Description	Code	QTY	Unit price in €	Total Price in €
	Lockable cabinet	LC-01		€ 150.00	€
	Stand built-in shelf	S-04		€ 65.00	€
	Refrigerator (100cm height)	RF-01		€ 135.00	€
	Show-case rack / Brochure holder	SR-01		€ 75.00	€
Total amount					€





Please note: Prices are excluding VAT (if applicable).

ORDER CONFIRMATION
Please note that, if applicable, sending back this order form automatically means that you agree that the order will be placed and/or invoiced.

AUDIOVISUALS & SUPPLIES		ORDER FORM 12	NON-OBLIGATORY
		To be returned before: Thursday February 27th, 2025.	
CONTACT	EMAIL	PHONE	
Mr. Juan Pablo Camacho	juanpablo@hpp.nl	+251-11-6620025	

Company Name:	
Stand number:	
Contact Person:	

If you wish to rent any of these appliances for your stand, please fill out the form bellow:

Image	Description	Quantity	Unit price in €	Total Price in €
	43" Smart TV		€ 135.00	€
	50" Smart TV		€ 170.00	€
	55" Smart TV		€ 270.00	€
	65" Smart TV		€ 335.00	€
			Total amount	€

Please note: Prices are excluding VAT (if applicable).

ORDER CONFIRMATION
Please note that, if applicable, sending back this order form automatically means that you agree that the order will be placed and/or invoiced.

STORAGE IN YOUR STAND		ORDER FORM 13	NON-OBLIGATORY
		To be returned before: Thursday February 27th, 2025.	
CONTACT	EMAIL	PHONE	
Mr. Juan Pablo Camacho	juanpablo@hpp.nl	+251-11-6620025	

Company Name:	
Stand number:	
Contact Person:	



	Description	Price in € per m ²	Total Price in €
<input type="checkbox"/>	Storage 1m x 1m with lockable door	€ 120.00	€
<input type="checkbox"/>	Storage 2m x 1m with lockable door	€ 170.00	€
Total amount			€

Please draw your stand to scale and indicate where you would like to have your storage:

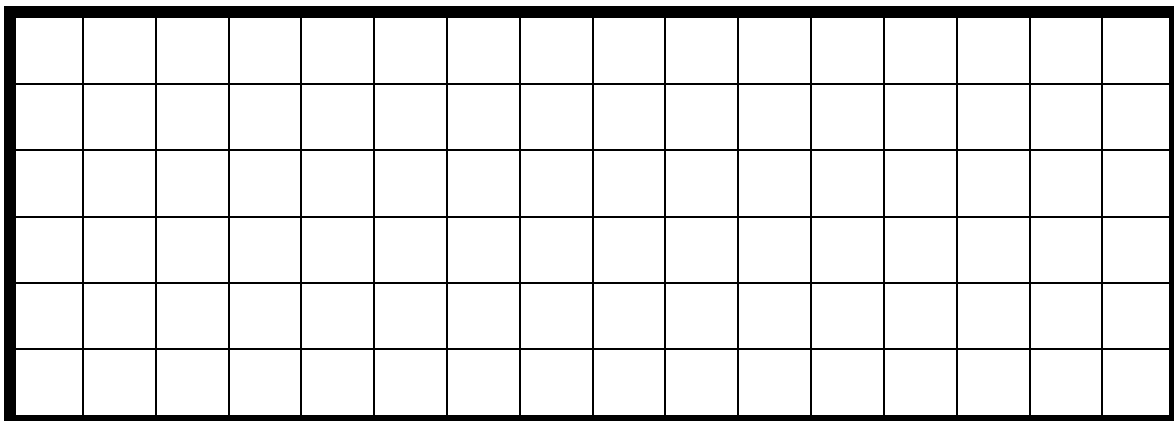

Please note: Prices are excluding VAT (if applicable).

ORDER CONFIRMATION

Please note that, if applicable, sending back this order form automatically means that you agree that the order will be placed and/or invoiced.

FLOWER DESIGNING		ORDER FORM 14 NON-OBLIGATORY	
		To be returned before: Thursday February 27th, 2025.	
CONTACT	EMAIL	PHONE	
Mr. Juan Pablo Camacho	juanpablo@hpp.nl	+251-11-6620025	

Company Name:	
Stand number:	
Contact Person:	

You can request professional flower designing for your stand on HORTIFLORA 2025. HPP offers the services of its professional team of designers as an extra way to highlight your participation.

The service includes: rental of wooden pillar (on the colour of choice), vase rental, flower designing, daily maintenance of the flower design and disposal of the flowers at the end of the exhibition.

YES, I would like be contacted for special flower designing needs and receive a quote.

ORDER CONFIRMATION
Please note that, if applicable, sending back this order form automatically means that you agree that the order will be placed and/or invoiced.